

## The Carpet-3 EAS array: the current status

---

**Viktor Romanenko<sup>a,\*</sup> on behalf of the Carpet-3 Collaboration**  
(a complete list of authors can be found at the end of the proceedings)

<sup>a</sup>*Institute for Nuclear Research of the Russian Academy of Sciences,  
60th October Anniversary Prospect 7a, Moscow 117312, Russia  
E-mail: [vsrom94@gmail.com](mailto:vsrom94@gmail.com)*

The Carpet-3 extensive air shower array is now under construction at the Baksan Neutrino Observatory. The array is located at the altitude of 1700 meters above sea level, and it consists of surface detection stations, situated close to each other for best sensitivity to extensive air showers with lower energy, and of an underground muon detector with a continuous area of 410 m<sup>2</sup>. The energy threshold for vertical muons is 1 GeV. The main aim of the experiment is to study the primary gamma radiation with energy above 100 TeV. The design of the Carpet-3 EAS array gives a possibility to carry out research on the composition of primary cosmic rays around the knee. It is planned that the Carpet-3 EAS array will be in full operation by the end of 2021. An overview of the current state of the experiment is presented, and its prospects are discussed.

*37<sup>th</sup> International Cosmic Ray Conference (ICRC 2021)  
July 12th – 23rd, 2021  
Online – Berlin, Germany*

---

\*Presenter

## 1. Introduction

Ultrahigh energy gamma-ray astronomy is of great interest for investigating the mechanisms of the origin of photons with energy above 100 TeV. One of the probable mechanisms of their origin is the decay of neutral pi mesons. In turn, they can be born either in hadron-hadron or in photon-hadron interactions and must be accompanied by a neutrino. In case of such a scenario, our Galaxy should exist acceleration sites of charged particles to several PeV are also called Galactic PeVatrons. Recent observations have not only predicted [1] such accelerators but also confirmed [2] their existence. But to create theoretical models, more observations are needed and, therefore, more facilities and experiments aimed at registering photons with energies of more than 100 TeV. The Carpet-3 extensive air shower (EAS) array is a new stage in the development of the old facility that has been operating since 1974. In this work, we provide an overview of the current state of the facility and future prospects.

## 2. Carpet-3 EAS array

The Carpet-3 EAS array located at the Baksan Neutrino Observatory, which is located near Mount Elbrus (North Caucasus) at the altitude of 1700 m above sea level and at coordinates  $43^{\circ}16'37.2''\text{N } 42^{\circ}41'24.0''\text{E}$ . It is a modernized and expanded facility that, in its initial configuration, began operations in 1974. During its the results [3, 4] were obtained which are of interest for gamma-ray astronomy. The most recent result - the observation of photons with energies over 300 TeV from the Cygnus Cocoon region [5], to be published in The Astrophysical Journal Letters.

Figure 1 shows the current layout of the Carpet-3 facility. It includes a surface array and an underground muon detector (MD). The facility uses two types of scintillation counters. The first one is a liquid scintillation counter of  $0.49 \text{ m}^2$  area (length and width are 70 cm) and 30 cm thickness. One vertical equivalent of muon (VEM) corresponds to 50 MeV (verified by Monte-Carlo simulation). The second one is a liquid scintillation counter of  $1 \text{ m}^2$  area (length and width are 100 cm) and 5 cm thickness where one VEM corresponds to 11 MeV.

### 2.1 The surface array

The surface array consists of a large square detector at the center (the Carpet array) of continuous area  $196 \text{ m}^2$  with 400 liquid scintillator counters. It is separated into 25 units with 16 counters in each. There are five detectors around the Carpet array, each of  $9 \text{ m}^2$  areas with 18 liquid scintillator counters. Four detectors are located at 30 m distance and one is at 40 m distance from the array center. Additionally, 39 detectors are installed, which consist of 9 plastic scintillator counters with an area of  $9 \text{ m}^2$ .

The block diagram of the data acquisition system of the surface array is shown in figure 2, right. The anode signals from the counters are summed up in each detector and by the cable transmitted to the hardware room, where anode signals are branched. The first one is connecting to an analog-to-digital converter (ADC) manufactured by CAEN, model V1742. Data from the ADC is preserved as a waveform for subsequent processing and determining the energy release in detectors. The second anode signal goes to the constant fraction discriminator (CFD) also manufactured by CAEN, model V816. The CFD is a timing discriminator whose threshold depends on the amplitude of the input

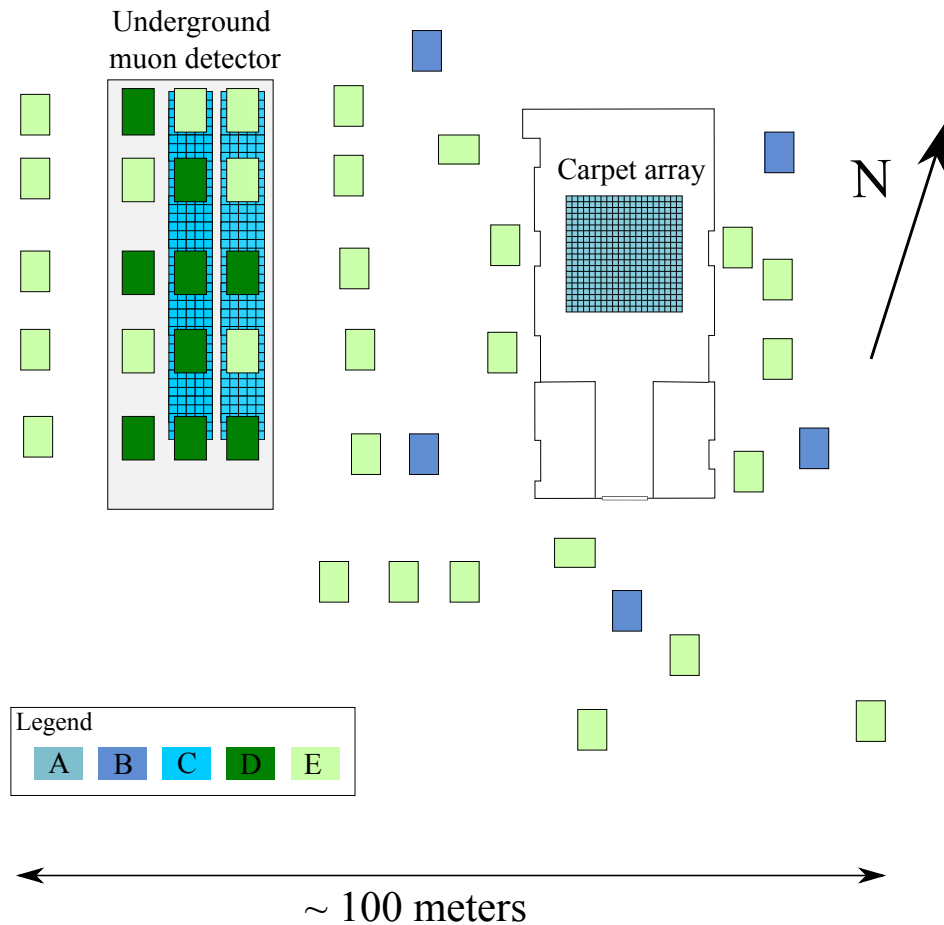
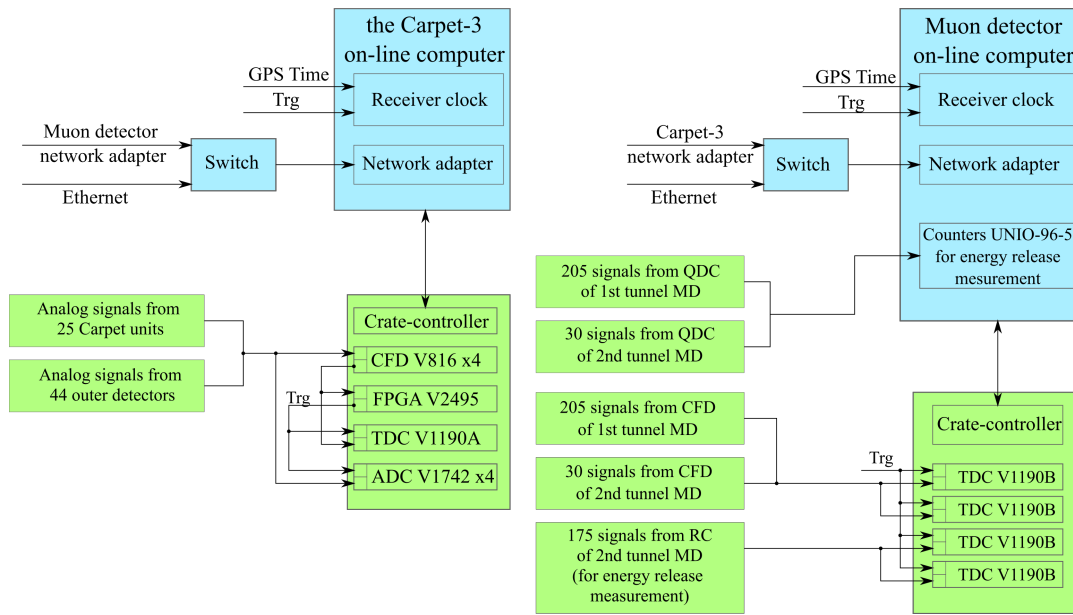

**Figure 1:** General scheme of the Carpet-3 facility. In the legend: (A) the Carpet array which consists of 400 liquid scintillator counters, (B) 5 ground detector with 18 liquid scintillator counters in each, (C) underground muon detector includes 410 plastic scintillator counters with a total area is 410 m<sup>2</sup>, (D) are ready to operate ground-based detectors with 9 plastic scintillator counters in each and (E) are detectors to be installed during 2021.

signal, what allows to measure a response time of the detector with more accuracy. It generates a logical signal, the rising edge of which corresponds exactly to the exceeding of the threshold. These signals are transmitted to a field-programmable gate array (FPGA, CAEN V2495) to generate the global trigger, and also to the time-to-digital converter (TDC, CAEN V1190A) for measuring the relative delays between triggered detectors and subsequent reconstruction of the arrival direction of the shower. The global trigger is a digital signal of the NIM standard, which is a command to save data from the ADC and TDC to their buffers. After reading, the data are saved in the memory of the Carpet-3 online computer.

## 2.2 The underground muon detector

The building of the muon detector consists of three tunnels, each with an effective area of 205 m<sup>2</sup> (41 m x 5 m). The thickness of the rock absorber above them is 500 m<sup>2</sup>, which corresponds



**Figure 2:** The block diagram of the Carpet-3 EAS array.

to the threshold energy of 1 GeV for vertical muons. At the moment, only two tunnels are completely filled with plastic scintillator counters, which are attached to the ceiling of the MD tunnel. The location of the MD counters relative to the surface array is shown in figure 1 (Legend: C). The block diagram of the data acquisition system of the muon detector is shown in figure 2, left. The first tunnel (closest to the Carpet array) is fully equipped with new kits of electronics (205 pieces). The second tunnel is partially equipped with new kits of electronics (35 pieces) and 175 old kits of electronics that worked in the previous configuration of the installation (Carpet-2). The new electronics kits consist of two modules. The first is a proprietary CFD that is used to determine the response time of an individual counter. Time delays are measured using TDC (TDC, CAEN V1190B), this will effectively eliminate accidentally triggered counters. The second is its own logarithmic charge-to-digital converter (LQDC). LQDC converts the charge of the anode signal into a sequence of logical pulses and the number of these pulses is proportional to the logarithm of the charge. These sequences of pulses are fed to the counters of logical pulses located in the online computer of the muon detector and then saved to a file.

### 3. Conclusion

The Carpet-3 air shower array is under construction at the Baksan Neutrino Observatory by step-by-step upgrade and extension. After the final accomplishment of this array, the installation will be sensitive to photons with energies of more than 100 TeV. This will allow us to study the origin of such photons, to measure the flux of cosmic diffuse gamma rays, as well as to perform other research on cosmic rays physics.

## **Acknowledgement**

The reported study was funded by RFBR, project numbers 20-32-90213 and 19-29-11027.

## **References**

- [1] Albert, A., et al. *The Astrophysical Journal Letters* 907.2 (2021): L30.
- [2] Cao, Zhen, et al. *Nature* (2021): L1.
- [3] Alexeenko, V. V., et al. *Il Nuovo Cimento C* 10.2 (1987): 151-161.
- [4] Alexeenko, V. V., et al. *Journal of Physics G: Nuclear and Particle Physics* 18.4 (1992): L83.
- [5] Dzhappuev, D. D., et al. ArXiv preprint arXiv:2105.07242 (2021), *The Astrophysical Journal Letters* (2021) in press.

### **Full Authors List: Carpet-3 Collaboration**

D. D. Dzhappuev<sup>1</sup>, Yu. Z. Afashokov<sup>1</sup>, I. M. Dzaparova<sup>1,2</sup>, T. A. Dzhatdov<sup>3,1</sup>, E. A. Gorbacheva<sup>1</sup>, I. S. Karpikov<sup>1</sup>, M. M. Khadzhiev<sup>1</sup>, N. F. Klimenko<sup>1</sup>, A. U. Kudzhaev<sup>1</sup>, A. N. Kurenya<sup>1</sup>, A. S. Lidvansky<sup>1</sup>, O. I. Mikhailova<sup>1</sup>, V. B. Petkov<sup>1,2</sup>, E. I. Podlesnyi<sup>4,3,1</sup>, G. I. Rubtsov<sup>1</sup>, S. V. Troitsky<sup>1</sup>, I. B. Unatlov<sup>1</sup>, I. A. Vaiman<sup>4,3</sup>, A. F. Yanin<sup>1</sup>, Ya. V. Zhezher<sup>1</sup> and K. V. Zhuravleva<sup>1</sup>

<sup>1</sup>Institute for Nuclear Research of the Russian Academy of Sciences, 60th October Anniversary Prospect 7a, Moscow 117312, Russia.

<sup>2</sup>Institute of Astronomy, Russian Academy of Sciences, 119017, Moscow, Russia.

<sup>3</sup>D.V. Skobeltsyn Institute of Nuclear Physics, M. V. Lomonosov Moscow State University, Moscow 119991, Russia.

<sup>4</sup>Physics Department, M. V. Lomonosov Moscow State University, Moscow 119991, Russia.