

LUCID: the ATLAS Luminosity Detector

Laura Fabbri, on behalf of the ATLAS Collaboration*

University of Bologna and INFN

E-mail: laura.fabbri@bo.infn.it

A precise measurement of the LHC luminosity is a key component of the ATLAS program: its uncertainty is a systematic error in all cross-section measurements, from the Standard Model processes to new discoveries, and for some precise measurements it can be the dominant error. To be predictive a precision compatible with PDF uncertainty (1-2%) is desired. LUCID (Luminosity Cherenkov Integrating Detector) is a luminometer sensitive to charged particles produced at the interaction point. It is the only ATLAS detector totally dedicated to this purpose and the main one during LHC RUN 2. After the RUN 1 shutdown, LUCID had to be redesigned in order to cope with the data taking conditions foreseen for RUN 2. The new detector, calibration system and electronics will be described, together with a preliminary result of the systematic uncertainty on the 2017 luminosity measurement.

*Sixth Annual Conference on Large Hadron Collider Physics (LHCP2018)
4-9 June 2018
Bologna, Italy*

*Speaker.

1. Introduction

Luminosity is a key quantity for many physics measurements since it directly enters the cross-section calculation together with the observed number of events. The uncertainty on the luminosity measurement represents the largest systematics in many physics analyses. For this reason, ATLAS provides several measurements of luminosity with LUCID as the main detector and the calorimeters and the inner detector providing additional measurements for the systematic evaluation.

Moreover, luminometers in ATLAS are crucial to provide fast online luminosity monitoring (1-2 seconds) to LHC, as required for efficient beam steering, machine optimisation and fast checking of running conditions such as monitoring the structure of the beam and beam-related backgrounds. Luminosity is also used in the ATLAS trigger to adjust the pre-scaling factors.

The increased energy of the proton beams and the higher luminosity of the LHC accelerator of RUN 2 required a redesign to cope with the more demanding conditions. The novelties of the LUCID-2 detector [1] are that thin quartz windows of photomultipliers are used as Cherenkov medium and a small amounts of radioactive ^{207}Bi sources are deposited onto these windows to monitor the gain stability of the photomultipliers. Thanks to new electronics, luminosity can be accurately measured, both online and offline, for each of up to 2808 colliding bunch pairs, 25 ns spaced.

2. Detector overview

LUCID [1] is composed of two modules (one of which is shown in Fig. 1) symmetrically positioned around the beam-pipe on both forward ends of ATLAS [2] at ± 17 m from the Interaction Point (IP).

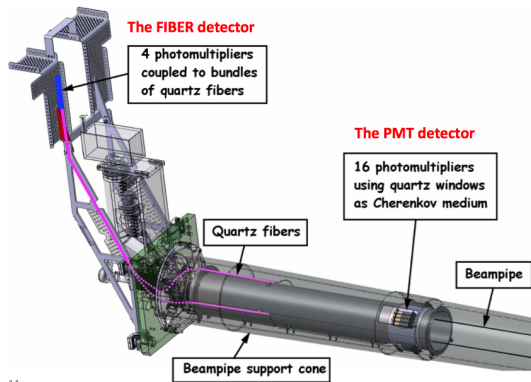

Figure 1: View of one of the two detector modules [1].

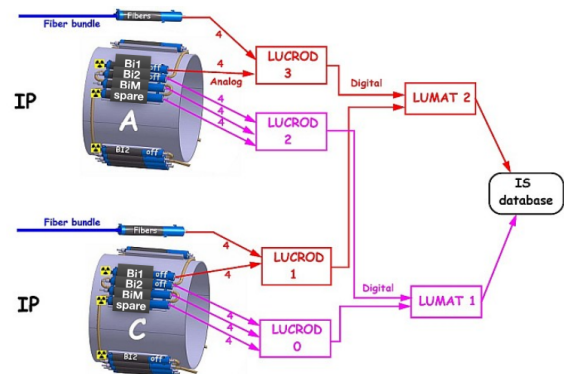

Figure 2: Diagram of the electronics [1].

In the new design, each module consists of two different subsystems: the PMT detector and the FIBER detector. The PMT detector is made of 16 photomultipliers (PMT), model R760 by Hamamatsu, arranged in 4 groups of independent sensors with different features: 4 + 4 standard PMTs, 4 spare PMTs, and 4 PMTs with reduced acceptance (partially opacified by a thin aluminium layer, in order to reduce the quartz window diameter from 10 mm to 7 mm). The quartz window of

the PMTs are used as Cherenkov radiators to detect charged particles produced in the interaction. All of them are equipped with ^{207}Bi radioactive sources for calibration purposes.

The FIBER detector uses 4 PMTs of the same model, fed by quartz fibers and located in a lower radiation area a few meters away. The quartz of the fibers is the radiator medium and also transmits light to the PMTs, while these sensors are calibrated via LED pulses.

The read out system (Fig. 2) consist of 4 new custom-made VME boards (known as LUCROD) placed 15 m from the PMTs. LUCRODs digitise signals (defining a hit if above a given threshold) and integrate the pulses every 25 ns (charge measurement), providing hit counting and charge measurement. Charge counting is proportional to luminosity and it is also insensitive to pile-up non-linearities, due to the absence of a threshold requirement. Hits are sent, via optical links, to other VME boards, known as LUMAT, located ~ 100 m away, which correlate hits coming from the two sides of LUCID. Hits and charges referring to each bunch-crossing and sensor are collected in the FPGAs of each board over periods of $\sim 1 - 2$ s and represent the raw-data for online determination of the luminosity. In addition, an independent stream dedicated to calibration and performance studies is available.

3. Calibration

Stability in the luminosity measurement at the % level requires corrections for gain loss or ageing, both affecting the PMTs during the data taking. The new LUCID detector is calibrated using an innovative technique that uses electrons from ^{207}Bi internal conversion. The ^{207}Bi emission allows accurate calibration of the PMTs since the energy of the emitted electrons (around 1 MeV) mimics the signal of high energy charged particles crossing the same quartz window. The calibration procedure consists of monitoring the mean value of the charge distribution collected by PMTs during dedicated sessions at the end of each LHC fill. Possible gain losses are automatically compensated through the increase of the high voltage to the PMTs. High voltage (HV) applied to the PMTs as a function of cumulative luminosity delivered by the LHC and absorbed radiation dose and charge produced by the PMTs, in the last three years are reported in Fig. 3.

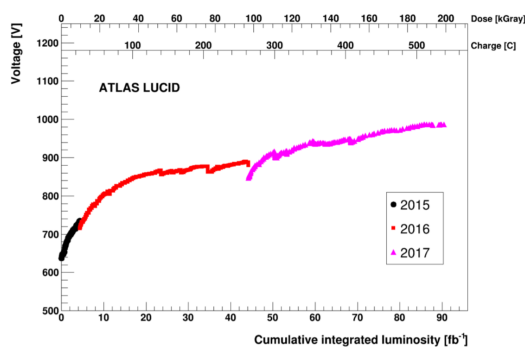

Figure 3: HV applied to the PMTs as a function of cumulative luminosity delivered by the LHC and of dose and charge, in the last three years. [1]

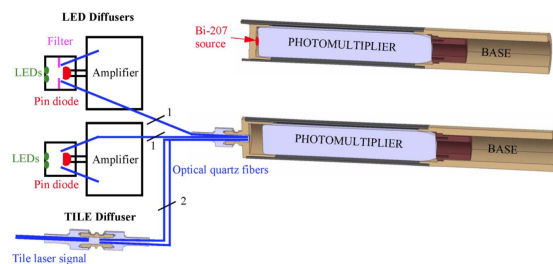

Figure 4: Schematics of the calibration system for the PMT detector on the top and the FIBER detector on the bottom. [1]

The FIBER detector is calibrated using LED pulses whose stability is monitored by Pin Diodes or laser signals from the Tile Calorimeter. For redundancy, two fibers come from two different LED diffusers and two fibers come from one laser diffuser (see Fig. 4).

4. Luminosity Measurement

Luminosity is related to the proton-proton inelastic rate (R) by the following equation:

$$L = \frac{R}{\sigma} \quad (4.1)$$

where σ is the cross-section of the process. It reflects the instantaneous performance of the collider. Operationally, it is evaluated in short periods, called luminosity-blocks (LB), and is computed as the sum of luminosity in each bunch crossing during these periods. For a collider, operating at a revolution frequency f_r and with n_b bunch pairs colliding per revolution, the luminosity can be expressed as:

$$L_{LB} = \frac{f_r}{\sigma^{inel}} \sum_{j=1}^{n_b} \mu_j \quad (4.2)$$

where μ_j is the average number of inelastic pp interactions per bunch-crossing and σ^{inel} represents the pp inelastic cross section. Due to acceptance and efficiency the observed interaction rate per crossing (μ^{vis}) differs from the real one and the equation becomes:

$$L_{LB} = \frac{f_r}{\sigma^{vis}} \sum_{j=1}^{n_b} \mu_j^{vis} \quad (4.3)$$

where $\mu^{vis} = \varepsilon \mu$ represents the number of visible inelastic interactions per bunch crossing multiplied by the acceptance and efficiency coefficient of a particular detector and algorithm, ε , and, similarly, $\sigma^{vis} = \varepsilon \sigma^{inel}$ is the visible inelastic cross section. It can be deduced from this equation that σ^{vis} is the absolute calibration constant and it can be obtained from dedicated LHC fills, called van der Meer scans. During these runs the beams are scanned across each other in the horizontal (x) and vertical (y) direction [3]. At each step the interaction rate and the beam separation (Δx or Δy) are measured. The basic idea is that the luminosity can be obtained from the width of the two scan curves if the number of colliding protons in the bunches is also measured. As can be seen in Fig. 5, the constant background rate from the ^{207}Bi sources is small enough not to spoil the measurement of the width of the scan curve.

LUCID estimates the rate of inelastic pp interactions in each bunch crossing using various algorithms: *Hit Counting*, *Event Counting* and *Charge Integration*. A "hit" is defined as a pulse above a given threshold, and an "event" is defined as a particular hit configuration. Hits and events can be related to the average number of interactions per bunch crossing (μ^{vis}) via Poisson statistics. Both methods are affected by pileup of several below-threshold signals which combine resulting in a spurious hit over threshold. Charge integration, instead, is the charge collected by each sensor at each bunch crossing and is directly proportional to the luminosity. All methods are used to evaluate luminosity and its systematics [4].

The redundancy of the measurement performed by different detectors and methods ensure a robust measurement of luminosity and an accurate control of systematic uncertainties. LUCID luminosity measurement is corrected by the Inner Detector (TRACKS), and is monitored by the calorimeters (EMEC, TILE, FCAL), and the detector called TPX. The fractional difference between LUCID and the other detectors reveals a run to run stability of 1.3% in 2017 and a consistency among luminosity measurements as a function of time as shows in Fig. 6.

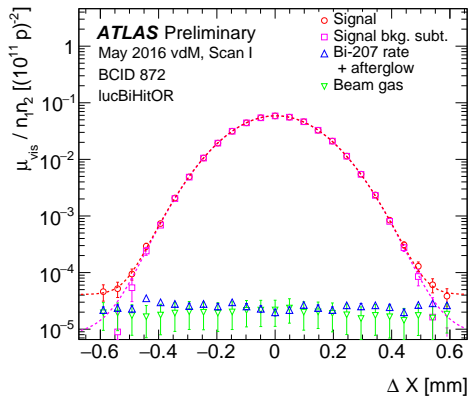

Figure 5: Visible interaction rate per bunch crossing during a beam scan as function of the beam separation Δx . Background from ^{207}Bi sources (blue points) is low enough not to spoil the precision of such a method [5].

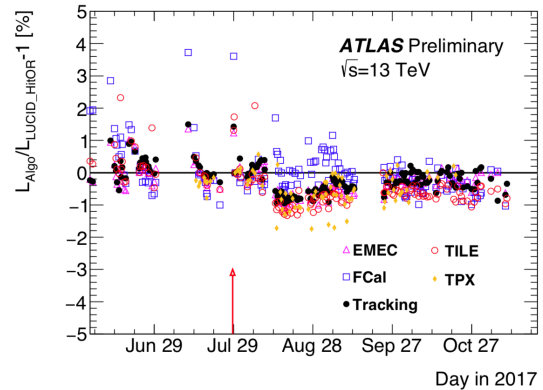

Figure 6: Fractional difference between LUCID and different detectors vs time [5].

5. Results

Since 2015, LUCID provides measurements of the ATLAS luminosity for physics analysis, and the instantaneous luminosity to LHC, for online beam stability monitoring, luminosity levelling and for the ATLAS trigger. Systematic errors in the pp data analysis are 2.1% and 2.2% in 2015 and 2016 respectively. Preliminary result for 2017 gives an uncertainty of 2.4% which will, very likely, be reduced, reaching or even improving the results of previous years.

References

- [1] G. Avoni et al, *The new LUCID-2 detector for luminosity measurement and monitoring in ATLAS*, JINST 13 (2018) P07017
- [2] ATLAS Collaboration, *The ATLAS Experiment at the CERN Large Hadron Collider*, JINST 3 (2008) S08003
- [3] S. van der Meer, *Calibration of the Effective Beam Height in the ISR*, CERN-ISR-PO-68-31
- [4] ATLAS Collaboration, *Improved luminosity determination in collisions at $\sqrt{s}=7$ TeV using the ATLAS detector at the LHC*, Eur. Phys. J. C 73 (2013) 2518
- [5] <https://twiki.cern.ch/twiki/bin/view/AtlasPublic/LuminosityPublicResultsRun2>